

Engate Fêmea para Painel de Máquinas.

código	cabo mm ²	Øa	sext.	Ø	amp. max*
WM 778	TBEM 10-25	32,0mm.	9/16"	9,0mm.	200
WM 775	TBE 35-70	38,0mm.	7/8"	13,0mm.	315
WM 781	TBE 70-95	38,0mm.	1"	13,0mm.	400

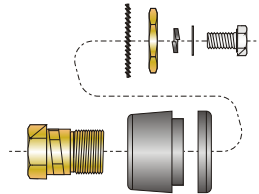

Engate rápido macho TSK

código	cabo mm ²	sext.	Ø	amp. max*
WM 771	TSKM 10-25	9/16"	9,0mm.	200
WM 780	TSK 50	7/8"	13,0mm.	315
WM 773	TSK 70	1"	13,0mm.	400
WM 669	TSK 95	1"	13,0mm.	400

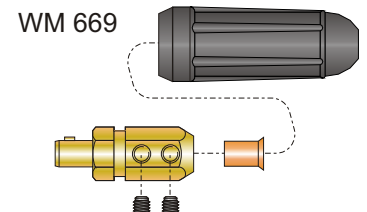
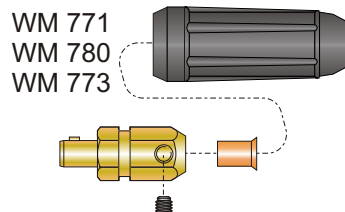
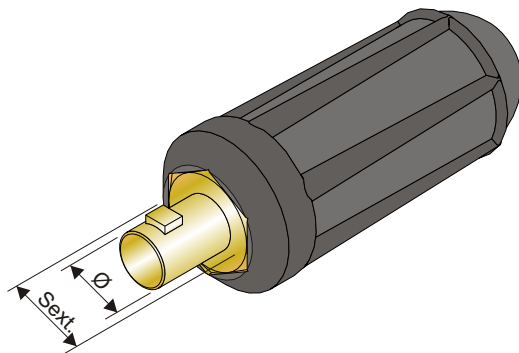

Engate rápido fêmea TBK

código	cabo mm ²	sext.	Ø	amp. max*
WM 776	TBKM 10-25	9/16"	9,0mm.	200
WM 777	TBK 50	7/8"	13,0mm.	315
WM 787	TBK 95	1"	13,0mm.	400

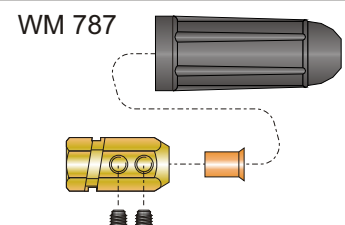
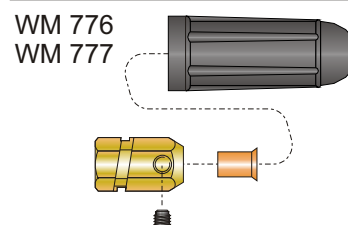
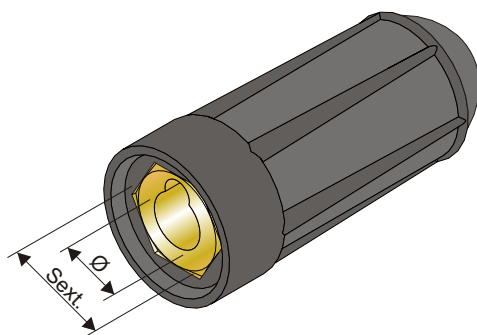

N.B.: Características técnicas sujeitas a modificação sem prévio aviso

ARQUIVO: (INFORMATIVO) CATALOGOS DIVERSOS \ ENGATES RÁPIDO

ELABORADO: Ricardo Z. Demeis | REVISÃO: 00 | DATA: 24/0324 | VISTO:

OXIMIG Indústria e Comércio Ltda - Rua Dona Ana Araujo de Paula, 523 - Vila Santa Clara - SP.

Fone: (0xx11) 6100-4824 Fax: (0xx) 6100-4824

E-mail: oximig@oximig.com.br

www.oximig.com.br